

## Conventional Current

- electric current is due to the flow of positive and negative charges.
- in metals, and most electrical circuits, only the negative electrons move.
- for historical reasons, the direction of an electrical current is the direction of the flow of positive particles (although the positive particles are *not* moving)
- conventional current is the direction that positive charges would move.
- symbol for current:  $I$

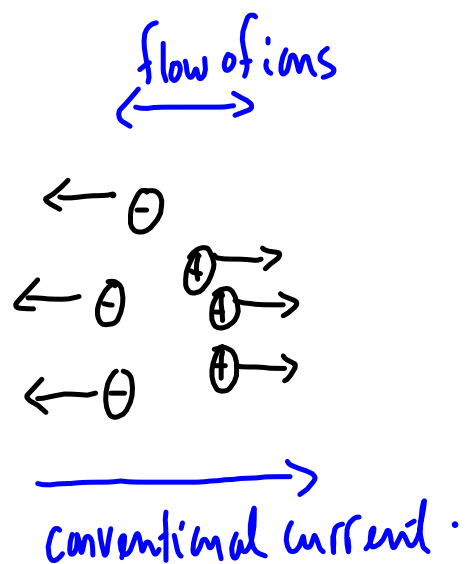
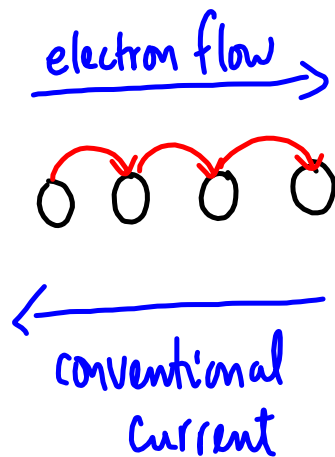

## An electric circuit

- electric charge is a conserved quantity  $\Rightarrow$  in any closed system the total charge remains constant.
- when electric current flows, no charges are added or taken away from the system.
- an electric current can only flow if there is a continuous closed circuit

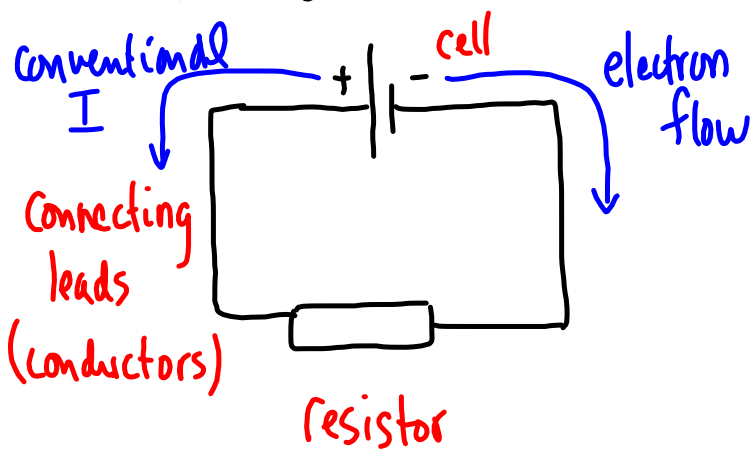

An electric current can flow in this circuit

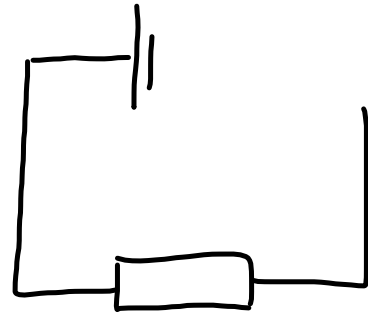

An electric current cannot flow (not closed)

Resistors in series:



Resistors in parallel:

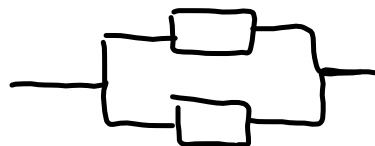

## Relationship between charge + current

- an electric current is the amount of charge that passes by a given point in one second. (this is a simple definition NOT the proper SI definition which is based on magnetic force)
- SI unit for current is the ampere, A (fundamental unit)
- SI unit for charge is the coulomb, C (derived unit)

Symbol:  $q$  or  $Q$

Definition of a coulomb:

One coulomb is the charge that passes a point if a current of 1 ampere flows for one second

(Recall: the coulomb is the derived unit and the ampere is the fundamental unit)

$$1\text{C} = 1\text{A} \times 1\text{s}$$

or:  $\Delta q = \bar{I} \Delta t$

$$\bar{I} = \frac{\Delta q}{\Delta t}$$

$$1\text{A} = 1\text{C s}^{-1}$$

## The elementary charge

- the coulomb is a very large unit of charge. It is the equivalent to the charge of about  $6 \times 10^{18}$  electrons.
- the charge on the electron is the same as the charge on a proton except that the electron is negatively charged and the proton is positively charged.
- the charge on an electron or a proton is called the elementary charge,  $e$ . This elementary charge is a fundamental constant. (see data booklet)

$$e = 1.60 \times 10^{-19} \text{ C}$$

Example:

What is the current if a charge of  $25 \text{ C}$  passes a point in  $5.0 \text{ s}$ ?

$$I = \frac{\Delta q}{\Delta t}$$

$$I = \frac{25 \text{ C}}{5.0 \text{ s}}$$

$$I = 5.0 \text{ A} \quad (\text{recall: } 1 \text{ A} = 1 \text{ C s}^{-1})$$

How many electrons pass a point in a wire per second if the current in the wire is  $500 \text{ mA}$ ?

$$I = \frac{\Delta q}{\Delta t} = 500 \text{ mA} = 500 \text{ mC s}^{-1}$$

$$\begin{aligned} \# \text{ of elementary charges} &= \frac{500 \times 10^{-3} \text{ C s}^{-1}}{1.60 \times 10^{-19} \text{ C}} \\ &= 3.10 \times 10^{18} \text{ s}^{-1} \end{aligned}$$

## A way to think about charges moving in an electric circuit

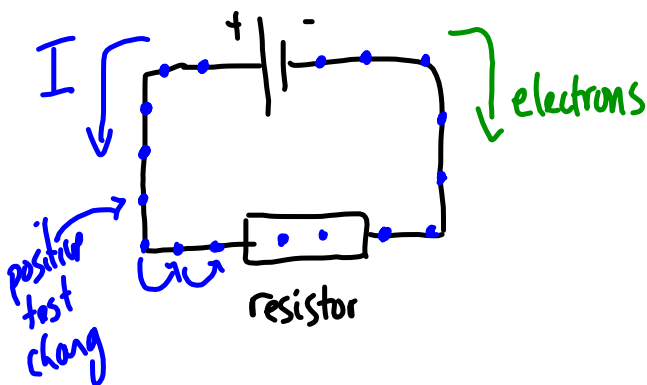

- If a small + test charge is placed in the circuit, it will move in direction of the conventional current.
- It is the electrons that are really moving in this circuit

Now consider a parallel circuit:

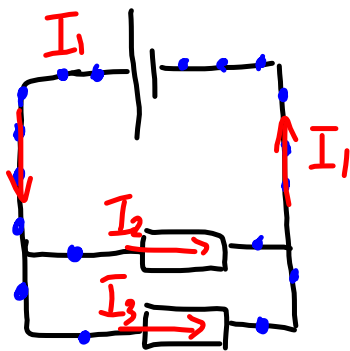

In a parallel circuit, some of the test charges pass through the top resistor and some through the bottom resistor  $\Rightarrow$  flow of charges split up  $\Rightarrow$  and then come back together.

The current splits

$$I_1 = I_2 + I_3$$

## Energy Transformations in an electric circuit

- a battery is a device that converts chemical energy into electrical potential energy.

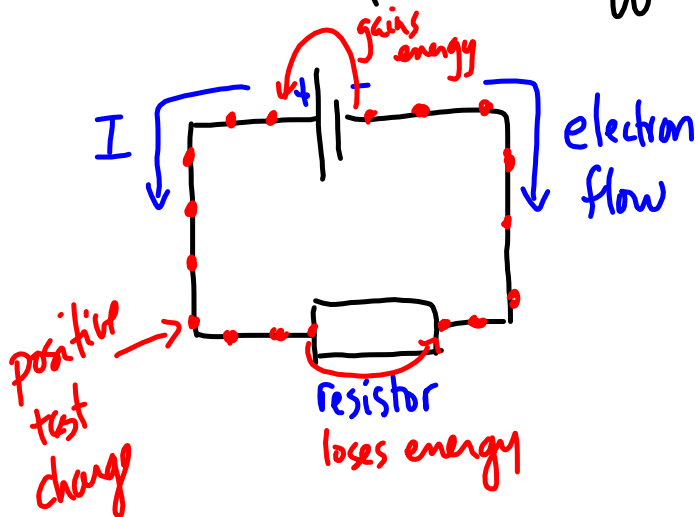

- the test charge gains electrical energy as it passes through battery
- as the test charges pass through the resistor, the resistor gets hot:

electrical energy  $\rightarrow$  thermal energy.

- By the time the test charge returns to the battery, its electrical potential energy is zero
- The electrical energy lost by the test charge as it passes through the connecting wires is considered to be zero, although that may not always be the case.  
(connecting wires have a <sup>very</sup> small resistance)
- each test charge loses electrical energy as it moves through the circuit.  
(the total energy lost is equal to the energy it gains in the battery)

